

A Study of the Kinetics of the Esterification of
Benzoic Acid with Methyl Alcohol.

A Thesis
Presented to
the Department of Chemistry
Washington and Lee University

In Partial Fulfillment
of the Requirements for the Degree
Bachelor of Science with
Honors in Chemistry

By
William C. Davison

May 3, 1967

Appreciation

A special thanks should be given to Doctor Thomas Cole Imeson, my advisor. His advice, inspiration and computer work on this project made it the success it was.

Vita

William C. Davison was born in Philadelphia, Pennsylvania on July 9, 1945. He attended public, elementary and high school in Haddonfield, New Jersey. He was graduated from Haddonfield Memorial High School on June 13, 1963. In September, 1963 he entered Washington and Lee University and began working toward a Bachelor of Science degree in Chemistry. In September of 1966 he became the first member of the Chemistry Department's newly formed honors program.

Theory

The reaction between methyl alcohol and benzoic acid to form methyl benzoate is perhaps the most fundamental of all esterification reactions.

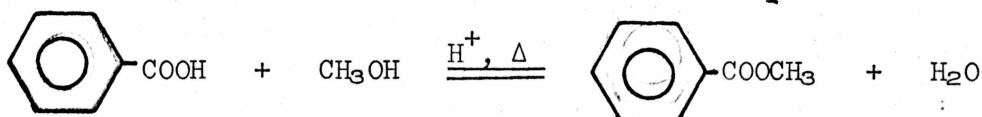

The forward as well as the reverse reaction is catalyzed by protons (H^+), this feature introduces complications by not allowing the reaction to approach completion from either direction.

The reaction mechanism is well known and consists of nucleophilic attack of the methanol oxygen on the carbonyl carbon of the acid with the elimination of a hydrogen from the methanol and the hydroxy group from the benzoic acid.

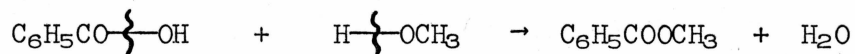

The theory involved in this is rather straight forward. The carbonyl oxygen of the acid is very electronegative thus allowing the loosely bound π electrons to be more closely associated with it. This leaves a partial positivity on the carbonyl carbon. This situation is made more acute by a proton attacking the carbonyl oxygen. The oxygen of the alcohol also has a high electron density due to its electronegativity, enabling this partial negative center to readily attack the carbonyl carbon. Thus, an intermediate is formed which has the general appearance of

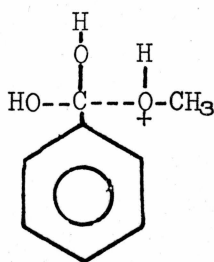

The original hydroxy group on the acid and the proton bonded to the alcohol's oxygen leave to form water and the ester is formed.¹ The proton catalyst remains in the vicinity creating the possibility of a reverse reaction.

The relative rates between the reverse and forward reactions involving benzoic acid, methanol and methyl benzoate are the main concern of this paper. The mechanism described in the preceding paragraph is called an S_N² mechanism. This is a two step process in which the first step, involving the collision between the acid and alcohol (ester and water in the reverse reaction), is the rate determining step. Since this collision is dependent on the concentrations of both substances it is called a bimolecular reaction and the rate can be said to be equal to the product of these concentrations and a constant which can be determined experimentally.

$$\text{rate} = k_1 [\text{Acid}][\text{Alcohol}]$$

There are two basic factors which enter into this reaction. One is the steric factor. The benzoic acid exists in a trigonal configuration with the intermediate formed after collision in a tetrahedral configuration. The large phenyl group on the acid makes this shift particularly difficult and considerable energy is required to achieve sufficient intermediate concentrations. Another factor has to do with the pi-system of the acid's phenyl ring. This system will probably be in conjugation with the carbonyl oxygen double bond. The effect of this is vague. Although this is likely to release more electrons and enhance the reactivity of the acid's carbonyl oxygen (due to oxygen's electronegativity), it will probably decrease

the reactivity of the nucleophilic attack on the carbonyl carbon by the alcohol. The rate constant, k_1 , will have to contain the effects of both these phenomenon.

Since both reactant concentrations affect the reaction rate, this reaction is of the second order. If we let a equal initial concentration of acid and b equal initial concentration of alcohol with x being the concentration of ester, then the initial integrated rate expression is determined in the following manner (assuming $a \neq b$)

$$\frac{dx}{dt} = k_1 [\text{Acid}][\text{Alcohol}] = k_1(a-x)(b-x)$$

$$\frac{dx}{(a-x)(b-x)} = k_1 dt$$

$$-\frac{1}{(a-b)} \int \left(\frac{1}{(a-x)} - \frac{1}{(b-x)} \right) dx = k_1 t$$

$$k_1 t = \frac{1}{(a-b)} \left[\ln \left(\frac{a-x}{b-x} \right) \right] + C$$

$$\text{when } t = 0 \text{ and } x = 0, C = \frac{\ln(b/a)}{(a-b)}$$

therefore, $2.303 (a-b) k_1 t = \log [(a-x)/(b-x)] + \log(b/a)$

Thus, from the plot $\log \frac{(a-x)}{(b-x)}$ vs t , we should get a straight line, with slope $2.303 (a-b) k_1$ and intercept $-\log(b/a)$.² It is in this manner that the rate constant, k_1 , is determined.

Returning to the esterification reaction, one should consider the potential energy diagram below. Region 1 of the curve represents the situation of the acid and alcohol existing independently, region 2 denotes the presence of reaction intermediate, and region 3 is the ester and water. The differences in the stabilities of the ester-water

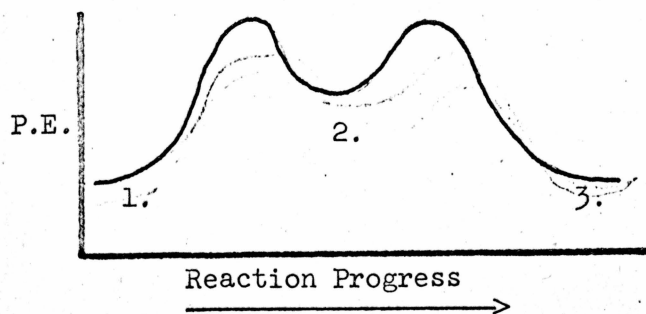

and the alcohol-acid combination should be nearly zero, thus implying very little total enthalpy change for the reaction. With this in mind let us consider how the reaction proceeds. The energy required to go from regions 1 to 2 is a form of activation energy. In a liquid state it is very hard to calculate the activation energy of a reaction because of the lack of good partition functions.³ This activation energy is dependent on the free energy changes in the reaction. In order for the reaction to proceed in any given direction, ΔG (change in free energy for the reaction) must be negative; and when the reaction is in equilibrium, the reaction ΔG is equal to zero. At the beginning of the reaction, the acid and alcohol collide producing the activated complex (providing sufficient interaction energy is available). This complex is in equilibrium with the reactant allowing an equilibrium constant to be calculated.

$$K^\ddagger = \frac{[\text{Complex}]}{[\text{Alcohol}][\text{Acid}]}$$

The complex is generally short-lived, dissociating into either products or reactants. Dissociation occurs when sufficient energy accumulates in a particular region to rupture a bond. Energy is made available through molecular vibrations. For a vibration to cause rupture, its frequency, ν , must be of the order of kT (where k is the Boltzmann constant and T the absolute temperature). Then the reaction rate becomes

$$-d[\text{Acid}]/dt = K^\ddagger \frac{kT}{h} [\text{Acid}][\text{Alcohol}]$$

with the rate constant being

$$k_1 = K^\ddagger \frac{kT}{h}$$

The free energy of activation is defined as

$$-RT \ln K^\ddagger \quad \text{or} \quad -RT \ln \frac{k_1 h}{kT}$$

A similar expression is also valid for k_2 which is the rate constant for the reverse reaction with ester and water as reactants, and the acid and alcohol products. Unfortunately, K^\ddagger cannot be evaluated for either the forward or reverse reaction, thus requiring an experimental determination of the rate constants. The relationships just discussed are only valid at the outset of the reaction. As soon as an appreciable amount of ester is formed a reverse reaction is set up. The rate equation for the complete reaction is

$$d[\text{Acid}]/dt = -k_1[\text{Acid}][\text{Alcohol}] + k_2[\text{Ester}][\text{Water}]$$

in which the k_1 and k_2 are the same rate constants mentioned previously.

Now we can define the forward rate as

$$d[\text{Acid}]/dt = -k_1[\text{Acid}][\text{Alcohol}]$$

with the reverse being

$$d[\text{Ester}]/dt = -k_2[\text{Ester}][\text{Water}]$$

When this system is in equilibrium

$$d[\text{Acid}]/dt = d[\text{Ester}]/dt$$

$$-k_1[\text{Acid}][\text{Alcohol}] = -k_2[\text{Ester}][\text{Water}]$$

$$K_{eq} = \frac{k_1}{k_2} = \frac{[\text{Ester}][\text{Water}]}{[\text{Acid}][\text{Alcohol}]}$$

This (K_{eq}) is the equilibrium constant for the whole reaction. When this state is reached there will be no net gain in the concentration of any component. One can look at this as a function of probability. At the start of the reaction when a few molecules of sufficient energy come together to form the complex, there is an equal probability of the complex forming the ester or breaking up into the reactants. If the ester is formed, it can be activated back to the complex. At first there is little probability that this will happen due to the low ester concentration

(less chance of it colliding with the catalyst) but as the ester concentration increases, the probability of the reverse reaction increases and an equilibrium is reached.

It is the purpose of this project to investigate the kinetics of this reaction using spectrometric techniques, and if possible to calculate the rate constant or constants.

Instrumental

A suitable detector or quantitative analyzer was sought for this project. It had to be able to determine the relative amounts of products and reactants quickly and accurately. If we were just concerned with our simple esterification reaction, a simple acid-base titration might have sufficed, but we were just as interested in developing a good technique of kinetic determination. For this reason we went to the field of infrared spectroscopy.

Washington and Lee University owns a Perkin-Elmer model 337 Infrared Spectrophotometer. The spectral range of this instrument is 4000 cm^{-1} ($2.5\ \mu$) - 400 cm^{-1} ($25\ \mu$) which covers the vibrational frequencies for most organic molecules. The instrument is simple in theory. An infrared light source is focused on a system of mirrors which divides the beam; one half going through the sample while the other passes through a reference (air). The beams then proceed to the photometer which sends them to the monochromator in pulses (one from sample, then one as reference) which continue to the detector. A graph of a series of wave numbers against percent transmittance results. A schematic diagram of this instrument can be seen in Figure 1.⁵

Since our reaction contained a fair amount of water, the normal infrared transparent crystals used would dissolve. Thus, an alternative system had to be devised. The method chosen was internal reflectance. This method can be likened to electromagnetic radiation striking a prism. The angle of incidence at the interface between the sample and the prism must be greater than the critical angle. All energy is then reflected; however, the ray does penetrate into the sample region (slightly), and if

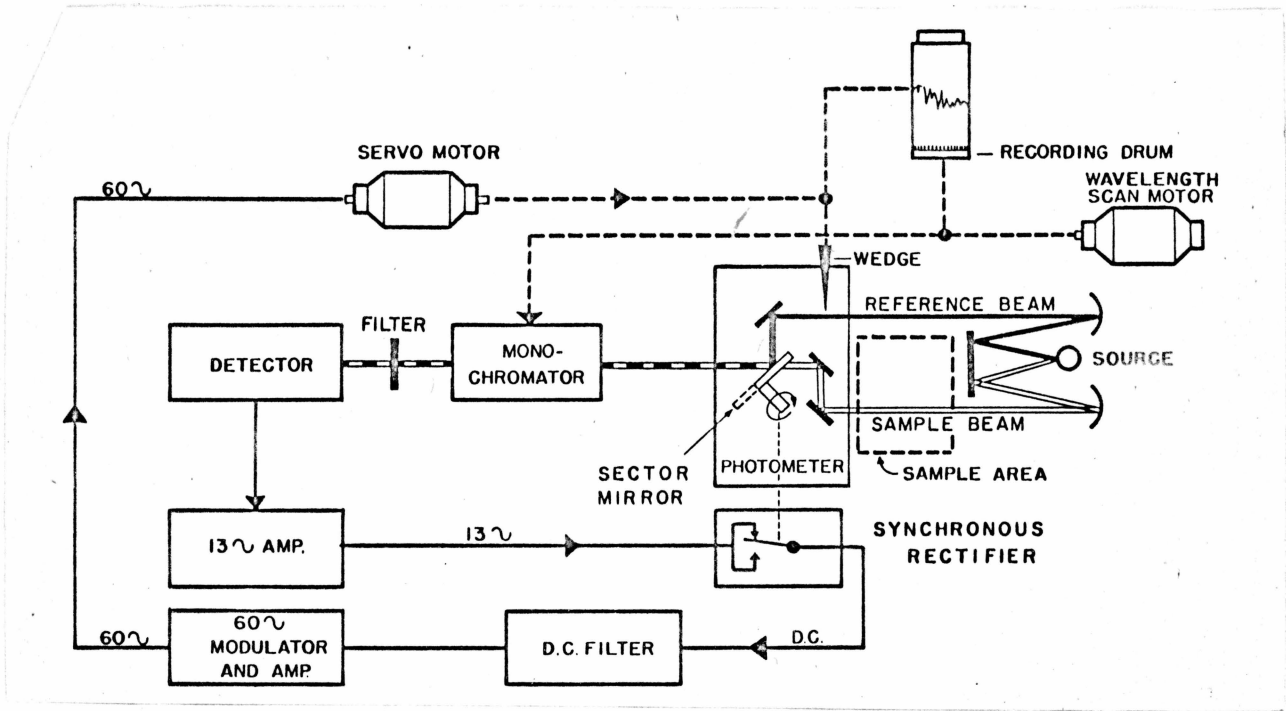
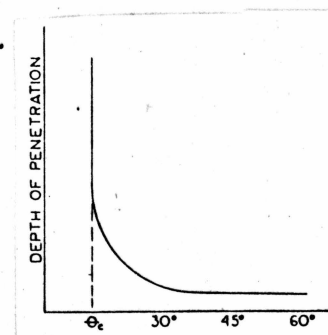

Figure 1

this region contains a radiation absorbing substance, some of the energy will be absorbed. This absorbed radiation can be measured by the spectrophotometer; the same way it measures radiation absorbed by a sample in a KBr cell (air as reference). The depth of penetration is dependent on three major factors: (1.) the wavelength of light, (2.) the refractive index of both the reflector and sample, and (3.) the angle of incident radiation. In this case the light wavelengths vary throughout the infrared regions of the spectrum or from 2.5μ to 25μ ; therefore, the energies are in the same relative magnitude (differing by no more than a factor of ten). Thus, the radiation from an instrument does not affect the penetration depth to any great degree. The refractive index of the reflector, crystal, can vary in three ways from that of the sample. It can be greater, equal to or less than that of the sample. If the refractive index of the reflector is less than the sample, nearly all the energy will be absorbed by the sample because there is no angle of incidence where internal reflection will take place. If the two refractive indexes are nearly equal, some distortion still exists. This happens on the long wavelength side of the band and a photon in this region acts as if the angle of incidence were increased. The only reflector refractive index which produces spectra nearly identical to absorption spectra is one which is much greater than the sample's. The angle of incidence should be selected so that it is much greater than the critical angle because as the critical angle is approached the depth of penetration increases (Figure 2). For the instrument used the angle of incidence is approximately 45° .⁶

Figure 2



The internal reflection spectroscopy device used is made by the Wilks Company and attaches very easily to the Perkin-Elmer 337 Spectrophotometer. A model of it can be seen in Figure 3.⁷ It consists of series of four mirrors. The first two mirrors receive the light from its source after it has been divided. (They are only concerned with the light going to the sample.) These mirrors focus the light through the sample holder, and the second two mirrors pick up the light as it leaves the sample holder and send it to the detector. The sample holder (Figure 4) is made of stainless steel and can be unscrewed to separate bilaterally,⁸ Between the two halves is placed a AgCl crystal which is used as the reflector and between the reflector and the holder is a space for the sample. The crystal's edges are cut in such a way as to achieve a 45° angle of incidence. Thus, the light goes through the crystal with

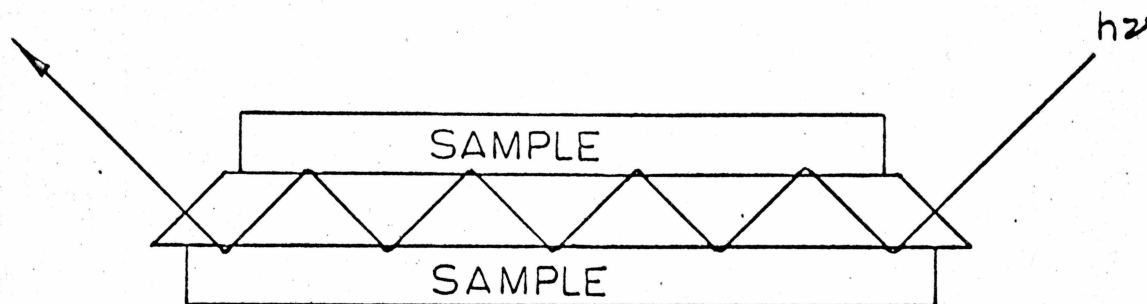

little sample penetration which allows for absorption at particular wavelengths.⁹

After experimenting with various concentrations of acid, alcohol, and ester solutions, it was decided to use the range from 3900 cm^{-1} to 1200 cm^{-1} . Two absorption peaks were considered in this range: one at 1700 cm^{-1} and the other at 1250 cm^{-1} . The 1700 cm^{-1} wave number light is absorbed by the C=O bond during stretching vibrations.¹⁰ This bond is present in both the

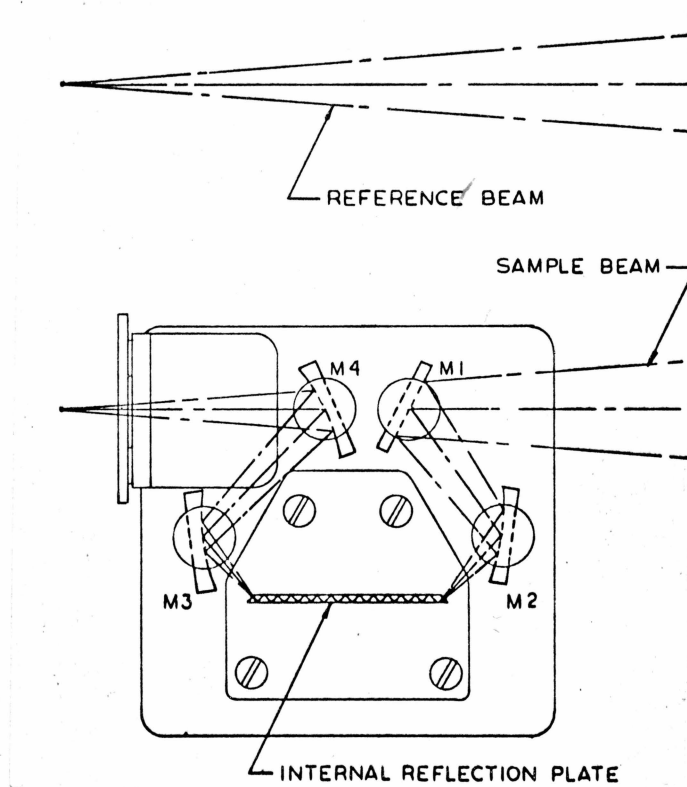

Figure 3

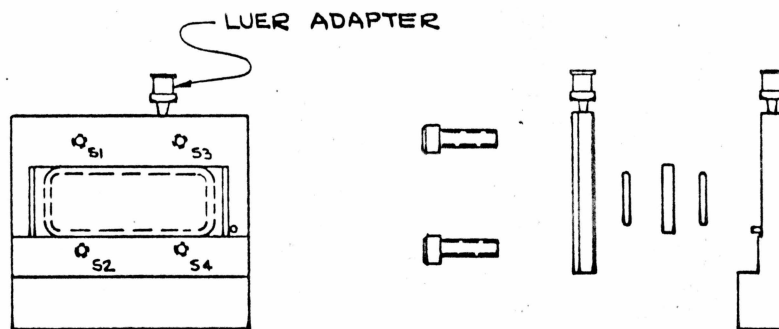
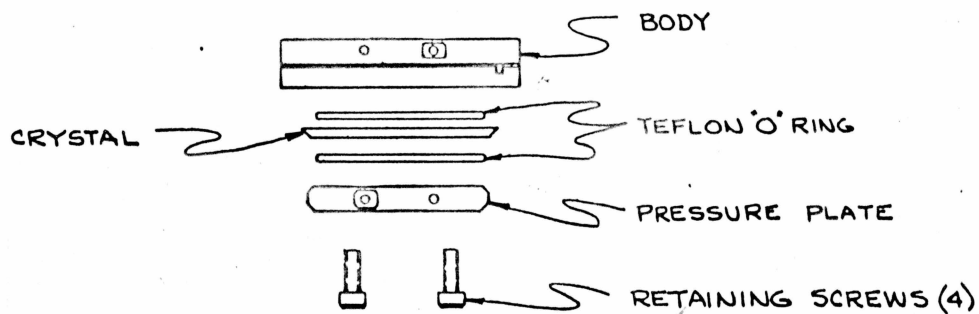

Figure 4

acid and the ester and no relationship was found between the percent transmittance and the ester concentration. If I_0 is used to indicate the amount of light striking the sample and I to indicate the amount of light not absorbed by sample, then the transmittance can be defined as $T = \frac{I}{I_0}$. Beer's Law states that $I = I_0 10^{-abc}$ with a = absorptivity, b = thickness of medium, and c being the concentration. A plot of $\log T$ vs. c should be linear if the law is followed.¹¹ Analysis of the absorption at 1700 cm^{-1} did not yield any Beer's Law behavior; therefore, another absorption peak had to be investigated.

The 1250 cm^{-1} peak was investigated next. This peak is the result of C-O stretching of ester, acids, and alcohols. Usually this band is very unstable in position, but the carbonyl bond found in esters seem to stabilize it; therefore, as the ester concentration increases so should the percent absorbance at 1250 cm^{-1} .¹² Acids also have the carbonyl which stabilizes the peak. Figure 5 shows the variation between acid concentration vs $\log (\%T)$ and ester concentration vs $\log (\%T)$ at 1250 cm^{-1} using methanol as a solvent. As one can see even though both plots are linear, they are not the same. Thus, a means of determining the ester concentration has been found and the kinetic investigation can begin.

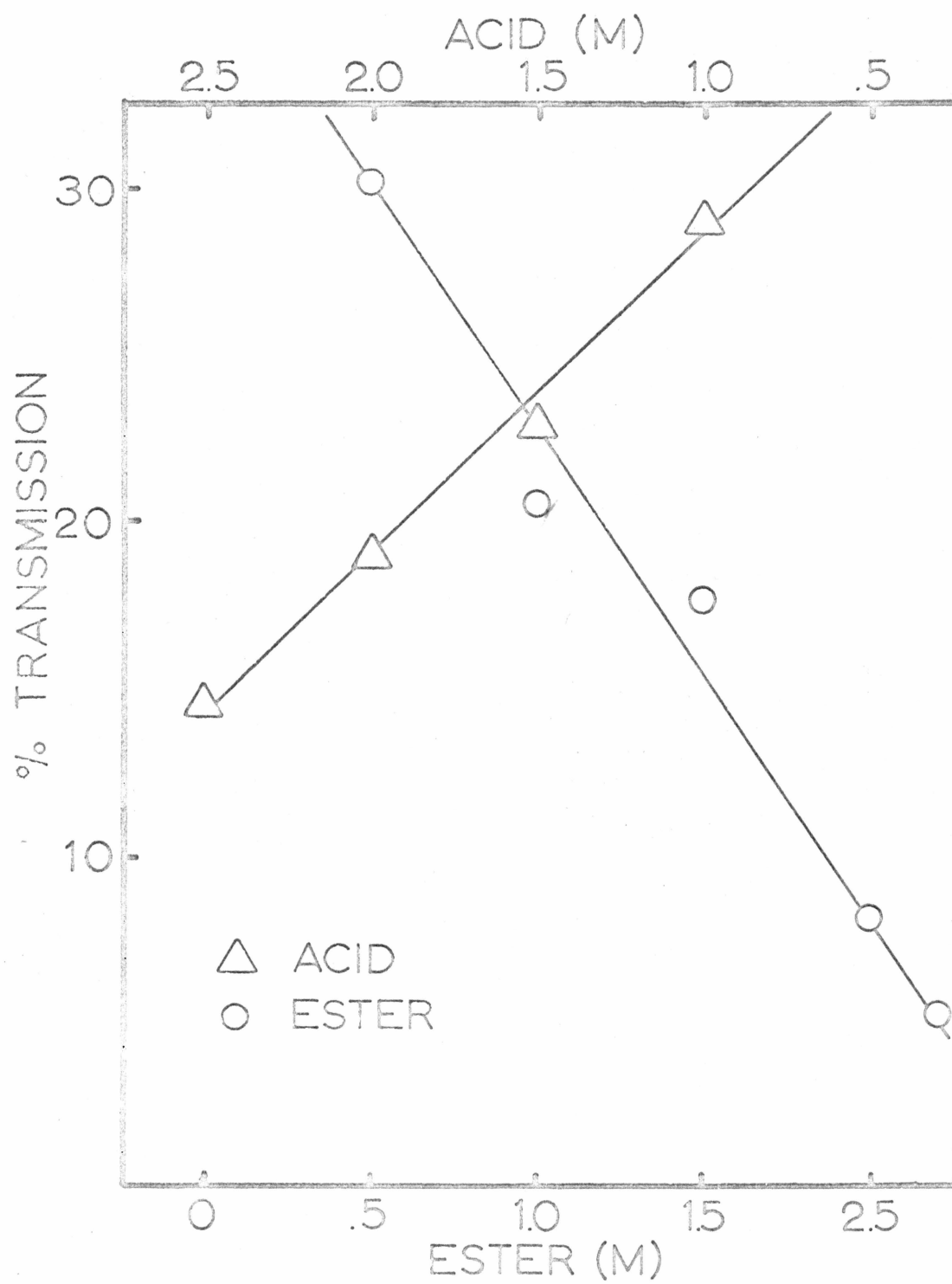

Figure 5

Experimental

Setting up a standardized plot of ester and acid concentrations vs percent transmittance was the first job. This was needed in order to relate a percent transmittance value for a reaction sample at a particular time to the exact concentrations of the sample. Solutions of the acid and the ester were quantitatively made up and placed in the internal reflectance device to ascertain the percent transmittance at 1250 cm^{-1} . The following tables show how these solutions were made and the constants and concentrations used.

Table I

Physical Constants

Methanol	Methyl Benzoate	Benzoic Acid
MW 32.04	MW 136.14	MW 122.12
Density .79 g/ml	Density 1.088 g/ml	

Table II

Milliliters of Methyl Benzoate	Concentration* (M)
.313	.50
.47	.75
.62	1.00
.93	1.50
1.09	1.75
1.25	2.00
1.36	2.20
1.56	2.50

Table III

Grams of Benzoic Acid	Concentration* (M)
.15	.25
.30	.50
.45	.75
.60	1.00
.92	1.50
1.21	2.00
1.53	2.50

*All quantities were calculated assuming five milliliters of solution with methanol as solvent.

Table IV

Mole Fraction of Ester	% Transmittance
0	15.8%
.2	14.5
.4	12.0
.6	9.2
.8	6.7
.9	5.5

Figure 6 is a Beer's Law plot of the data in Table IV. This plot will be used for the standardization of any reaction concentrations. It should be noticed that a second degree polynomial can also be fitted to the data. This should be investigated in any further consideration of the reaction; however, there is no apparent reason to leave the Beer's Law plot. Both the line and the second degree polynomial were fitted to the calibration data, and the second degree polynomial fit provided the least deviation. When these two fits were used with the experimental data, the linear fit produced the least deviation (see Appendix). On this basis it was decided that the linear plot had more apparent consistency with the experimental data; therefore, more emphasis was put on these calculations. The area where the deviation is greatest is the area of low ester concentration. By comparing the curves for pure acid and ester (Figure 5) with the ester-acid mixture curve (Figure 6), it is noticed that they do not have the usual triangular relationship with the mixture curve beginning at the 2.5 M ester concentration and ending at the 2.5 M acid concentration of the "pure" curves. The reasons for this are obscure, but there seems to be some interaction between the acid and ester to effect the percent transmittance in a slightly different manner than when just a pure solute is used. This phenomenon should not have any effect on the

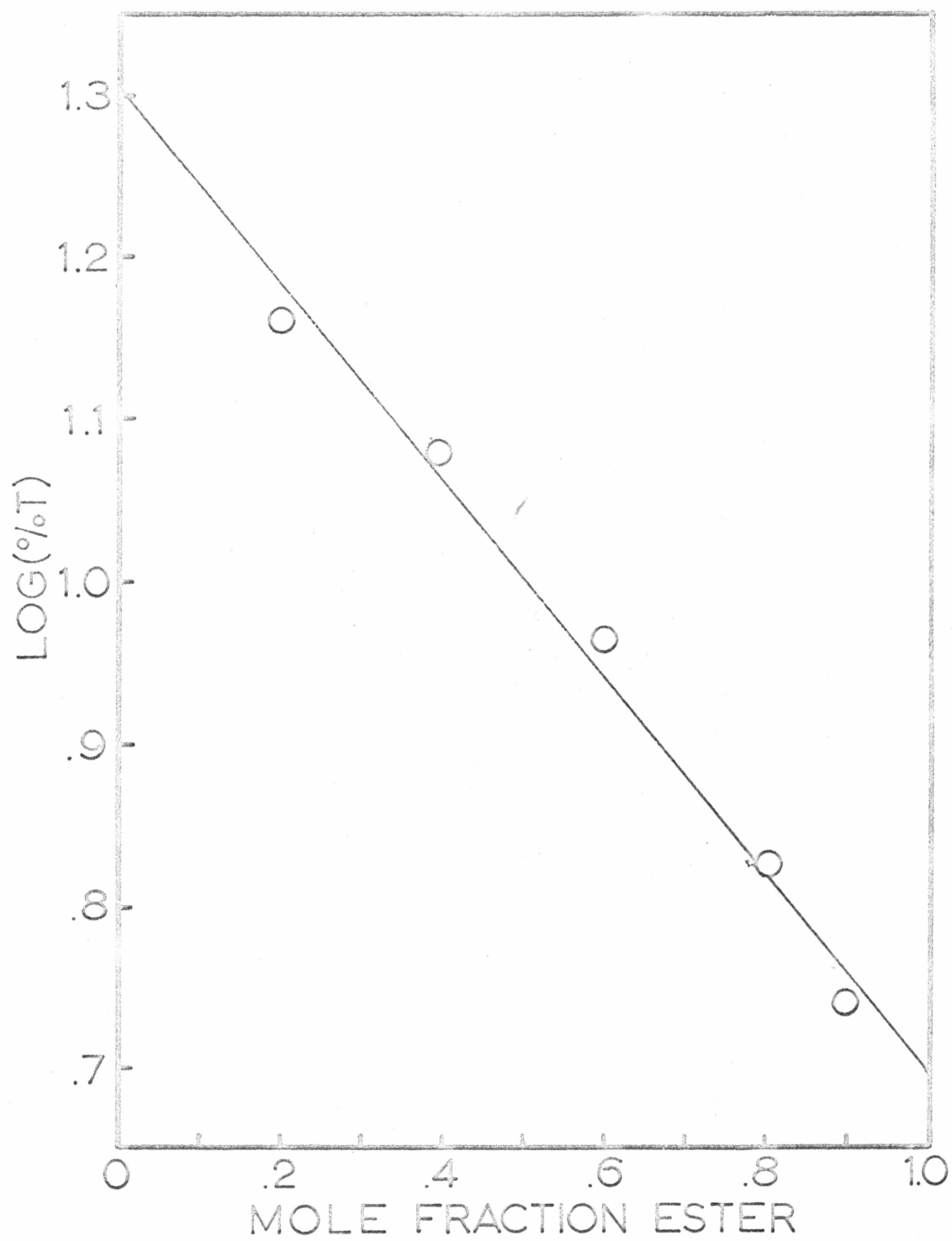

Figure 6

accuracy of the standardization.

When the reaction was ready to be run, 30.53 grams of benzoic acid was mixed with 100 milliliters of methanol. This mixture was put into a 250 milliliter ground glass flask upon which was set a Claisen connecting tube. In one neck of the connecting tube was placed a 200 millimeter distilling column set for reflux, and in the other neck was placed a straight tube adapter with a centigrade thermometer. The flask was set in a heating jacket attached to a rheostat which was set to 55 volts. The solution initially boiled at 63.40°C; at this point a sample was taken from the flask. This was the zero time sample (about 3 milliliters) and was placed in an ice-salt bath ($\sim -10^{\circ}\text{C}$) in order to freeze the reaction. After the initial sample was taken, .9 milliliters of concentrated sulfuric acid catalyst was added. Further samples were taken at periodic intervals and placed in the ice-salt bath. Using the internal reflectance device on the infrared apparatus a spectrum was obtained on slow speed from 3900 cm^{-1} to 1200 cm^{-1} and the percent transmittance at 1250 cm^{-1} was noted (see Figure 7).

The experimental data was treated assuming the standard data to be linear. Four runs were made of the reaction.

Table V

Run 1		Run 2		Run 3		Run 4	
time(minutes)	%T	time	%T	time	%T	time	%T
0	9.5	0	13.5	0	12	0	13.5
5	7.6	5	12.5	5	11		
15	7.0	15	9.0	15	10.1	15	9.0
30	5.0	30	7.0	30	8		
64	4.6	60	4.0	60	6.6	60	7.0
93	4.2	123	3.6	123	5.9	91	6.0
120	4.0	225	2.8	225	5.7		

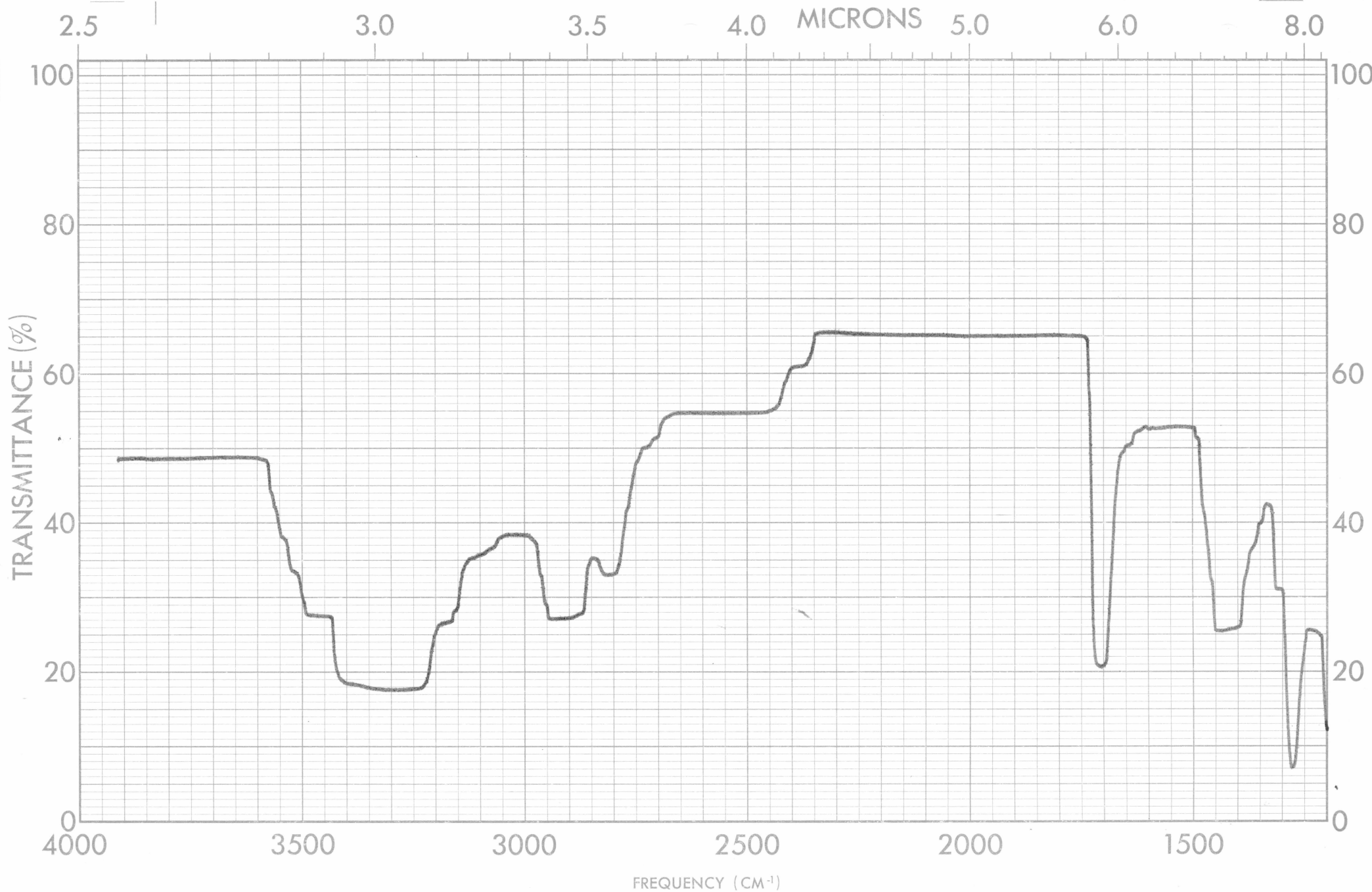

SAMPLE <u>Methyl Benzoate and</u>	CURVE NO. <u>Figure 7</u>	SCAN SPEED <u>Slow</u>	OPERATOR <u>W C D</u>
<u>Benzoic Acid</u>	CONC. _____	SLIT <u>Narrow</u>	DATE _____
ORIGIN _____	CELL PATH _____	REMARKS _____	
SOLVENT <u>Methyl Alcohol</u>	REFERENCE _____	_____	

In order to analyze this data accurately and efficiently a computer program (see Appendix) was employed. This program performed the following operations:

1. Fit the calibration data to a quadratic and linear equation and printed a table which contained the weight of acid, the volume of ester, the mole fraction of acid and ester, percent transmittance at 1250 cm^{-1} , the $\log(\%T)$ and the root mean square deviation. (It also calculated the average absolute deviation))
2. Assumed that the mole fraction of ester at zero time to be zero and calibrated the percent transmittance of the run to fit the calibration line.
3. Set the calibrated data of the run to a least squared linear equation of the $\log \frac{(a-x)}{(b-x)}$ vs. time plot.
4. Calculated and printed the time, the percent transmittance, the moles of ester, the $\log [(a-x)/(b-x)]$, the deviation, the rate constant, the predicted intercept ($-\log b/a$), and the experimental intercept. These data sheets can be seen in the Appendix.

When all the data are considered, a good linear fit is not obtained; Figure 8 is an indication of this. The data up to sixty minutes are fairly linear, but after that they are not. This is due to the increasing influence of the reverse reaction and the approaching of equilibrium. The effects of k_2 can be seen as these values vary from linearity. As time increases the plot should approach a straight line parallel to the time axis; therefore, in order to investigate k_1 we only used data values up to sixty minutes.

The following rate constants were calculated by the program.

Run	$k_1(\text{M}^{-1}\text{min}^{-1})$
1	1.09×10^{-4}
2	1.63×10^{-4}
3	$.91 \times 10^{-4}$
4	$.93 \times 10^{-4}$

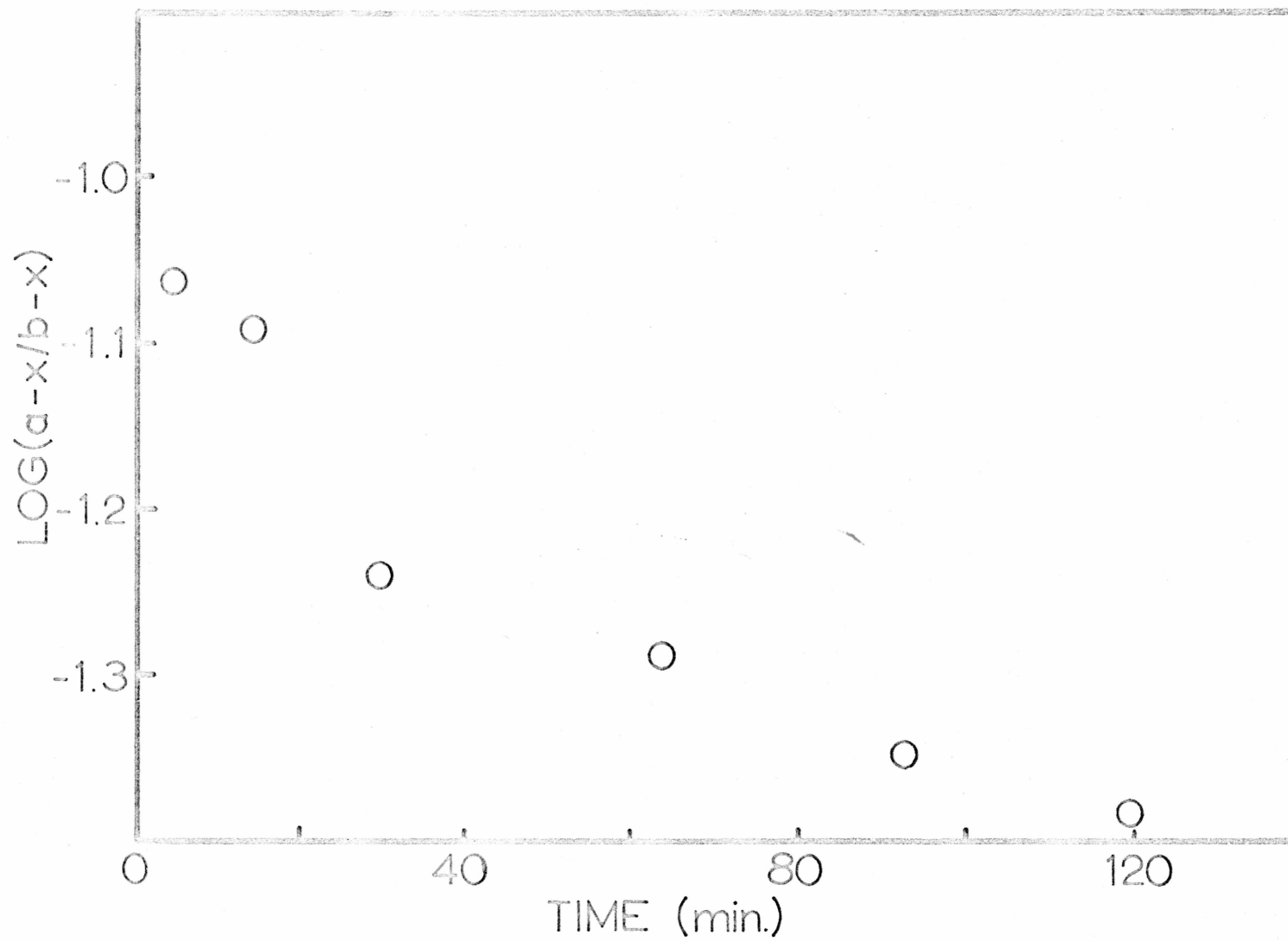

Figure 8

As can be seen these values are all in the same relative area, but they are not real close. All these runs were not made under the same conditions; the procedure was perfected as different runs were made. The first three runs of the reaction solution were heated by a Bunsen burner flame and the zero time sample and catalyst were taken and added before heating began. Only the fourth run contained the procedure explained in the experimental section. Since this run almost duplicates the third run's value, it is indicated that the rate constant is somewhere in the area of $.9 \times 10^{-4}$. Figures 9-12 are plots of $\log \frac{(a-x)}{(b-x)}$ vs. time for the various runs. It is the slope of these lines which is used in the rate constant determination. There are many factors which can effect these slopes. Some of the more important ones are: the temperature of the reaction which varied greatly in the four runs and can only show consistency if a heating jacket is used, the amount of catalyst used which is directly proportional to the number of molecular interactions taking place in unit time (since the reaction used very small amounts of catalyst, the amount was very critical), and the amount of starting materials used which was affected by accuracy of the measuring instruments. These factors must be considered in any future runs.

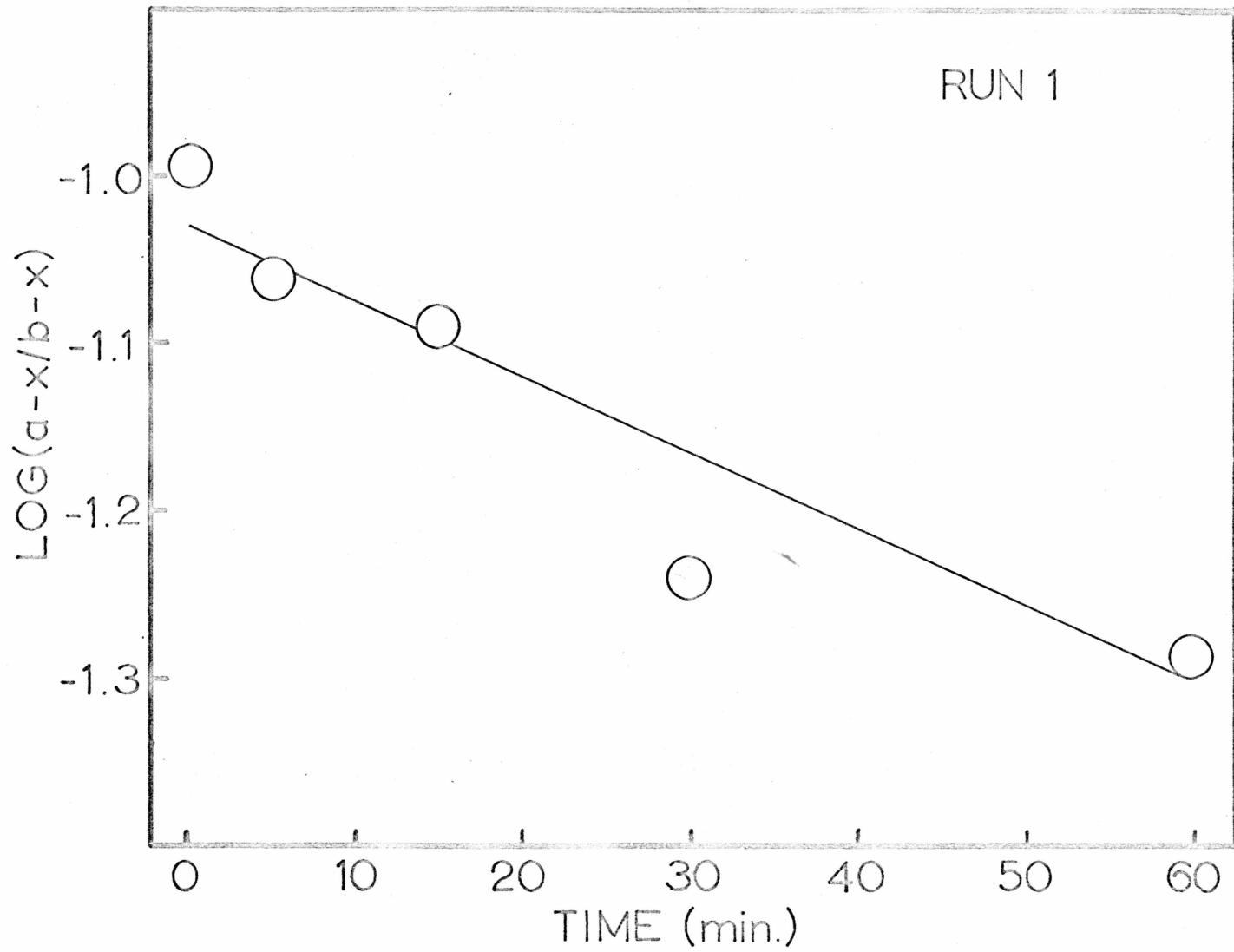

Figure 9

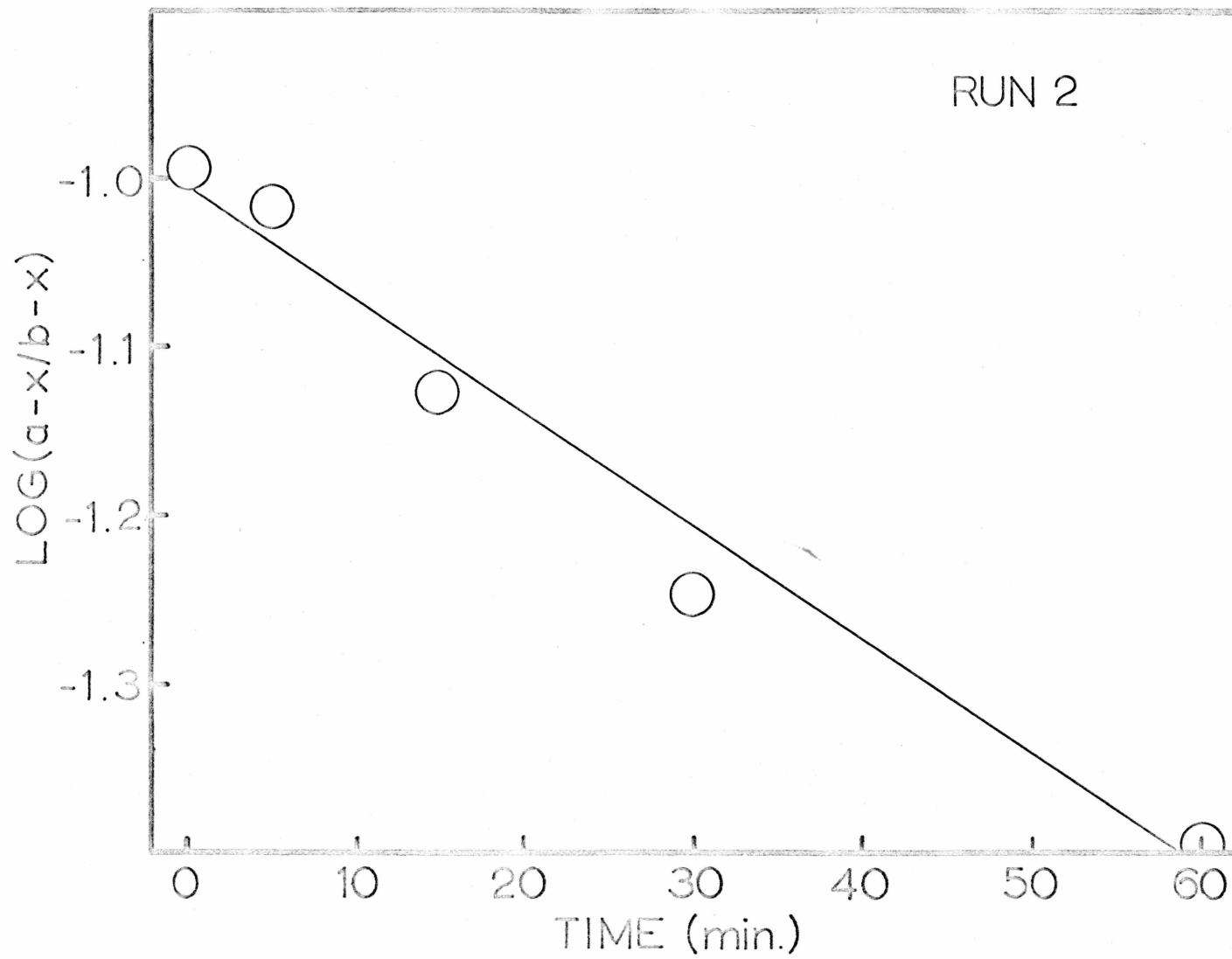

Figure 10

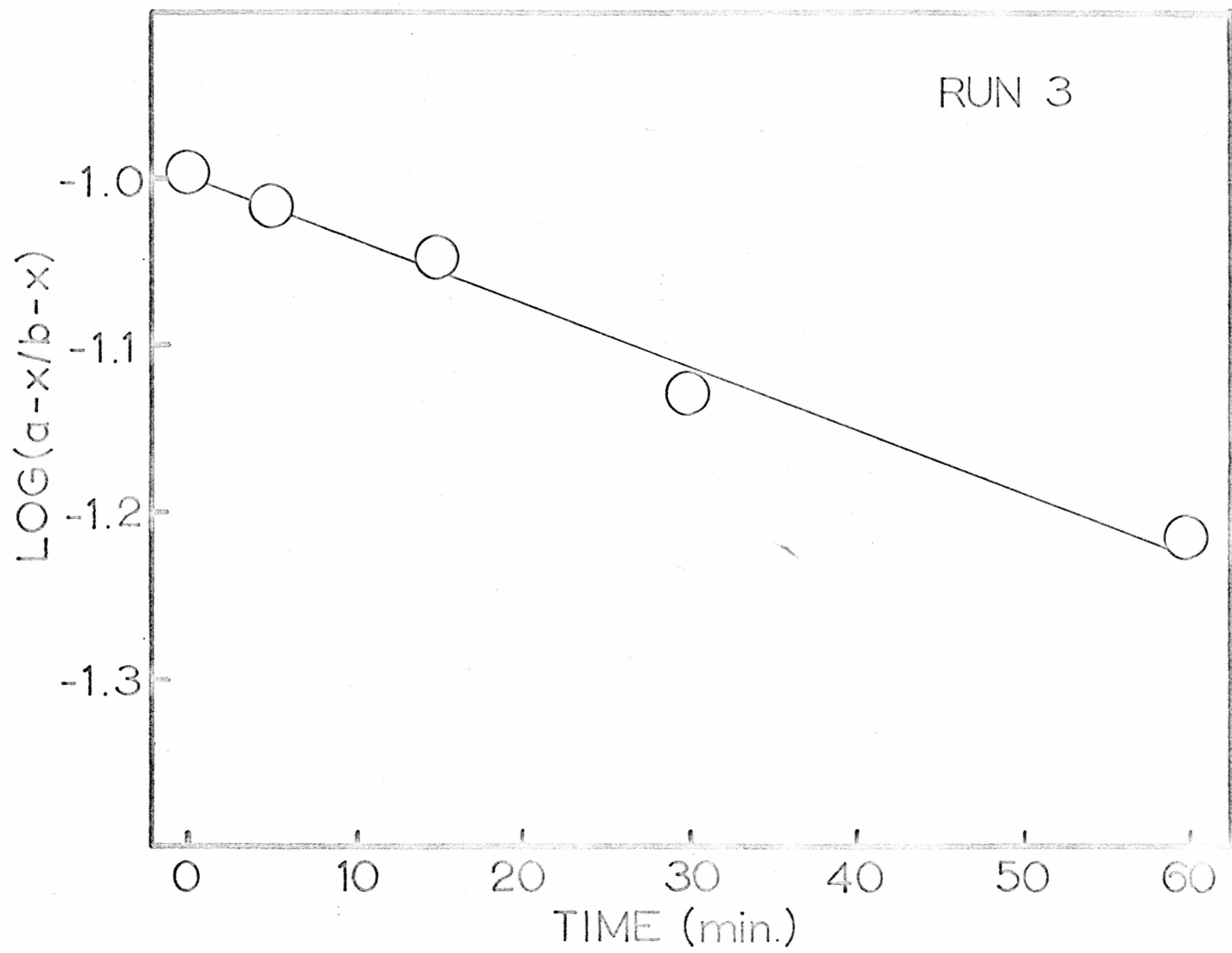

Figure 11

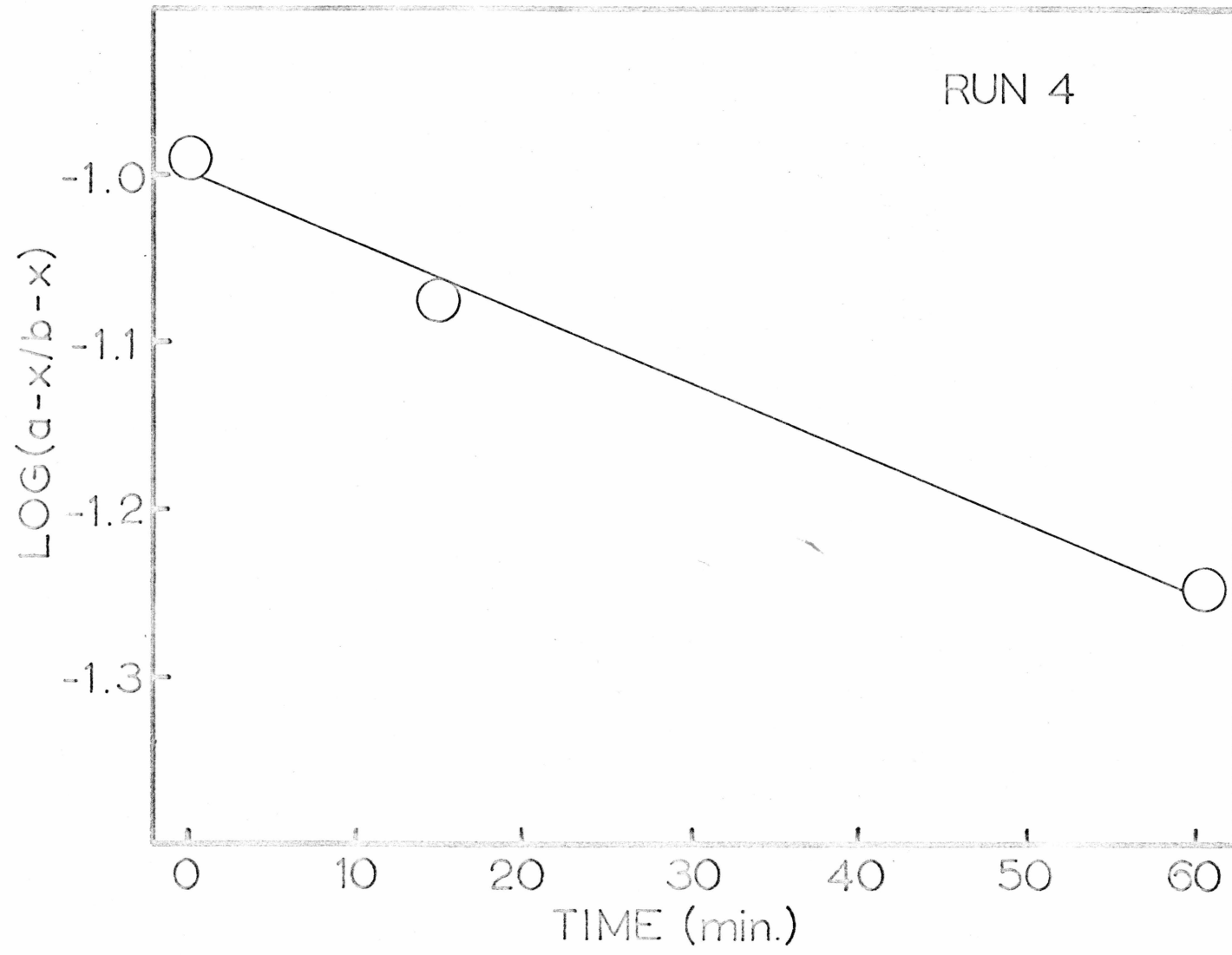

Figure 12

Conclusion

As has already been stated, there is some evidence that the value of the rate constant, k_1 , is near $.9 \times 10^{-4} \text{ M}^{-1} \text{ min}^{-1}$. The major source of error was probably the internal reflectance method used. The internal reflectance unit has too many variables to get good reproducible and completely reliable quantitative results. This unit was chosen primarily for the inexpensive water insoluble AgCl crystal which it employed. The crystal introduced another source of error in that it reacted with light to precipitate silver; consequently, the composition of the crystal was constantly changing with time. There were other obvious sources of error such as the making up of the calibration solutions, but these were small compared to those of the internal reflectance unit.

The procedure itself should be fairly sound, and it should be tried using a water insoluble crystal in a cell which attaches directly to the infrared apparatus.

As an indication of the reliability of the rate constant determined for the system under investigation, the uncertainty in k_1 for run four is calculated below. The equation used is ¹³

$$\frac{\Delta k_1}{k_1}^2 = \left(\frac{t_1}{t_2 - t_1}\right)^2 \left(\frac{\Delta t_1}{t_1}\right)^2 + \left(\frac{t_2}{t_2 - t_1}\right)^2 \left(\frac{\Delta t_2}{t_2}\right)^2 + \left(\frac{A_2}{A_2 - A_1}\right)^2 \left(\frac{\Delta A_1}{A_1}\right)^2 + \left(\frac{A_1}{A_2 - A_1}\right) \left(\frac{\Delta A_2}{A_2}\right)^2$$

where $k_1 = .86 \times 10^{-4}$

$t_1 = 15$ minutes

$\Delta t_1 = .5$

$t_2 = 60$

$\Delta t_2 = .5$

$A_1 = .072$ moles

$\Delta A_1 = .005$ moles

$A_2 = .117$ moles

$\Delta A_2 = .008$ moles

so that,

$$\frac{\Delta k_1}{k_1} = .112 \text{ or } 11.2\%$$

If the assigned limits of error are correct the rate constant should be uncertain only in the second place.

Appendix

This section contains the computer programs used for the evaluation of the experimental data included in Tables I-VI. After each program, there is included a sample of the printed output obtained from the program. Each of these programs are written in PDQ Fortran and were used on the IBM 1620 computer located at Washington and Lee University.

```

C      CALIBRATION METHYL BENZOATE SYSTEM
C      LEAST SQUARE FIT TO LINEAR AND QUADRATIC
      DIMENSION W(20),V(20),T(20),XB(20),Y(20),X(20),DEV(20)
1000 READ 1, N, NM, ND, NY
      1 FORMAT(I2,2X,I2,2X,I2,2X,I2)
      PRINT 30, NM, ND, NY, N
      30 FORMAT(11H DATA TAKEN,2X,I2,1H/,I2,1H/,I2,10X,16HNUMBER OF POINTS,
12X,I2//)
      DO 41 I = 1, N
      READ 2, W(I), V(I), T(I)
      2 FORMAT(F5.2,5X,F6.2,5X,F6.2)
      BM = W(I)/122.12
      EM = V(I)*1.087/136.14
      XB(I) = BM/(BM + EM)
      Y(I) = EM/(BM + EM)
41 X(I) = LOG(T(I))/2.303
      EXECUTE PROCEDURE 102
      PRINT 20,A0,A1,A2,RMSD
      20 FORMAT(12H CALIBRATION//17H LEAST SQUARE FIT/,
123H MOLE FRACTION ESTER = ,E11.5,3H + ,E11.5,7H*LOG(T),3H + ,
3E11.5,10H*LOG(T)**2,/10X,7HRMSD = ,E10.5//)
      PRINT 21
      21 FORMAT(28X,13HMOLE FRACTION/2X,9H ACID WT.,2X,10HVOL. ESTER,4X,
14HACID,6X,5HESTER,5X,9HPC TRANS.,4X,6HLOG(T),7X,4HDEV./)
      EXECUTE PROCEDURE 100
      PRINT 28
      28 FORMAT(/13X51HCOORDINATES OF POINTS GENERATED BY LEAST SQUARE FIT/,
122X,6HLOG(T),8X,19HMOLE FRACTION ESTER/)
      H = 0.
      DO 46 J = 1, 11
      G = (-A1 - SQRT(A1**2 - 4.*A2*(A0 - H)))/(2.*A2)
      PRINT 29, G, H
      29 FORMAT(20X,E11.5,10X,E11.5)
      46 H = H + .1
      PUNCH 80, A0, A1, A2, NM, ND, NY, N
      80 FORMAT(E11.5,2X,E11.5,2X,E11.5,2X,5HQUAD.,3X,1H2,
15X,I2,1H/,I2,1H/,I2,10X,I2)

```



```

CONTROL 971
EXECUTE PROCEDURE 101
PRINT 24, A0, A1, RMSD
24 FORMAT(17H LEAST SQUARE FIT/5X,22HMOLE FRACTION ESTER = ,E11.5,
13H + ,E11.5,7H*LOG(T),2X,7HRMSD = ,E10.5//28X,13HMOLE FRACTION/2X,
29H ACID WT.,2X10HVOL. ESTER, 4X,4HACID,6X,5HESTER,5X,9HPC TRANS.,
34X,6HLOG(T),7X,4HDEV./)
EXECUTE PROCEDURE 100
PRINT 28
H = 0.
DO 47 J = 1, 2
G = -(A0 - H)/A1
PRINT 29, G, H
47 H = 1.
PUNCH 81, A0, A1, NM, ND, NY, N
81 FORMAT(E11.5,2X,E11.5,14X,6HLINEAR,3X,1H1,
15X,I2,1H/,I2,1H/,I2,10X,I2)
CONTROL 971
BEGIN PROCEDURE 100
DO 42 I = 1, N
PRINT 22, W(I), V(I), XB(I), Y(I), T(I), X(I), DEV(I)
22 FORMAT(1X,5E11.5,1X,E11.5,1X,E11.5)
42 CONTINUE
PRINT 23, AVG
23 FORMAT(49X,20HAVERAGE DEVIATION = ,E11.5)
END PROCEDURE 100
BEGIN PROCEDURE 101
C LEAST SQUARE FIT  $Y(I) = A0 + A1*X(I)$ 
SUMY = 0.
SUMX = 0.
SUMY2 = 0.
SUMX2 = 0.
SUMXY = 0.
DO 141 I = 1, N
SUMY = SUMY + Y(I)
SUMY2 = SUMY2 + Y(I)**2
SUMX = SUMX + X(I)

```

```

SUMX2 = SUMX2 + X(I)**2
141 SUMXY = SUMXY + X(I)*Y(I)
U = N
DEN = U*SUMX2 - SUMX**2
AO = (SUMY*SUMX2 - SUMXY*SUMX)/DEN
A1 = (U*SUMXY - SUMX*SUMY)/DEN
SUMD2 = 0.
SUMD = 0.
DO 142 I = 1, N
DEV(I) = Y(I) - (AO + A1*X(I))
SUMD2 = SUMD2 + DEV(I)**2
142 SUMD = SUMD + ABS(DEV(I))
RMSD = SQRT(SUMD2/U)
AVG = SUMD/U
END PROCEDURE 101
BEGIN PROCEDURE 102
C LEAST SQUARE FIT TO SECOND DEGREE POLYNOMIAL
C Y = AO + A1*X + A2*X**2
X1=0.
X2=0.
X3=0.
X4=0.
Y1=0.
XY=0.
X2Y=0.
DO 241 I = 1, N
X1=X1+X(I)
X2=X2+X(I)**2
X3=X3+X(I)**3
X4=X4+X(I)**4
Y1=Y1+Y(I)
XY=XY+X(I)*Y(I)
241 X2Y=X2Y+Y(I)*X(I)**2
U=N
DEN=U*(X2*X4-X3**2)-X1*(X1*X4-X2*X3)+X2*(X1*X3-X2**2)
AO=(Y1*(X2*X4-X3**2)-X1*(XY*X4-X2Y*X3)+X2*(XY*X3-X2*X2Y))/DEN
A1=(U*(XY*X4-X2Y*X3)-Y1*(X1*X4-X2*X3)+X2*(X1*X2Y-X2*XY))/DEN

```

```
A2=(U*(X2*X2Y-XY*X3)-X1*(X1*X2Y-X2*XY)+Y1*(X1*X3-X2**2))/DEN
D=0.
D2=0.
DO 242 I = 1, N
DEV(I)=Y(I)-(A0+A1*X(I)+A2*X(I)**2)
D=D+ABS(DEV(I))
242 D2=D2+DEV(I)**2
RMSD=SQRT(D2/U)
AVG=D/U
END PROCEDURE 102
STOP
GO TO 1000
END
```

DATA TAKEN 3/ 10/ 67

NUMBER OF POINTS 5

CALIBRATION

LEAST SQUARE FIT

MOLE FRACTION ESTER = .67464E 00 + .15484E 01*LOG(T) + -.16818E 01*LOG(T)**2
RMSD = .50277E-01

ACID WT.	VOL. ESTER	MOLE FRACTION		PC TRANS.	LOG(T)	DEV.
		ACID	ESTER			
.15000E 00	.14000E 01	.99004E-01	.90099E 00	.55000E 01	.74022E 00	.16727E-02
.30000E 00	.12500E 01	.19752E 00	.80247E 00	.67000E 01	.82592E 00	-.38173E-02
.60000E 00	.93000E 00	.39819E 00	.60180E 00	.92000E 01	.96361E 00	-.32955E-02
.92000E 00	.62000E 00	.60346E 00	.39653E 00	.12000E 02	.10789E 01	.91246E-02
.12000E 01	.31000E 00	.79879E 00	.20120E 00	.14500E 02	.11611E 01	-.38602E-02
AVERAGE DEVIATION =						.43541E-02

COORDINATES OF POINTS GENERATED BY LEAST SQUARE FIT

LOG(T)	MOLE FRACTION ESTER
.12433E 01	.00000E-50
.12043E 01	.10000E 00
.11633E 01	.20000E 00
.11196E 01	.30000E 00
.10729E 01	.40000E 00
.10222E 01	.50000E 00
.96661E 00	.60000E 00
.90402E 00	.70000E 00
.83101E 00	.80000E 00
.73950E 00	.90000E 00
.59625E 00	.10000E 01

LEAST SQUARE FIT

MOLE FRACTION ESTER = .21475E 01 + -.16425E 01*LOG(T) RMSD = .29757E-00

ACID WT.	VOL. ESTER	MOLE FRACTION		PC TRANS.	LOG(T)	DEV.
		ACID	ESTER			
.15000E 00	.14000E 01	.99004E-01	.90099E 00	.55000E 01	.74022E 00	-.30709E-01
.30000E 00	.12500E 01	.19752E 00	.80247E 00	.67000E 01	.82592E 00	.11534E-01
.60000E 00	.93000E 00	.39819E 00	.60180E 00	.92000E 01	.96361E 00	.37021E-01
.92000E 00	.62000E 00	.60346E 00	.39653E 00	.12000E 02	.10789E 01	.21257E-01
.12000E 01	.31000E 00	.79879E 00	.20120E 00	.14500E 02	.11611E 01	-.39100E-01
AVERAGE DEVIATION =						.27924E-01

COORDINATES OF POINTS GENERATED BY LEAST SQUARE FIT

LOG(T)	MOLE FRACTION ESTER
.13074E 01	.00000E-50
.69865E 00	.10000E 01

```

C      EVALUATION OF EXPERIMENTAL DATA      METHYL BENZOATE SYSTEM
C      DETERMINATION OF RATE CONSTANT
      DIMENSION T(20),Y(20),X(20),ESTM(20),DEV(20)
1000 READ 2, A0, A1, A2, M, NM, ND, NY, N
      2 FORMAT(E11.5,2X,E11.5,2X,E11.5,10X,I1,5X,I2,2X,I2,2X,I2,10X,I2)
      IF(M - 1) 70,70,71
      70 PRINT 22, NM, ND, NY, N
      22 FORMAT(17H CALIBRATION DATE,2X,I2,1H/,I2,1H/,I2,10X,6HLINEAR,10X,
116HNUMBER OF POINTS,2X,I2//)
      GO TO 72
      71 PRINT 23, NM, ND, NY, N
      23 FORMAT(17H CALIBRATION DATE,2X,I2,1H/,I2,1H/,I2,10X,5HQQUAD.,10X,
116HNUMBER OF POINTS,2X,I2//)
      72 READ 3, WA, VM, VHSO, N, NM, ND, NY
      3 FORMAT(F6.3,5X,F6.2,5X,F3.1,5X,I2,5X,I2,2X,I2,2X,I2)
      TM = WA/122.12
      AMEM = VM*.792/32.04
      VOL = WA/1.316 + VM + VHSO
      AI = TM*1000./VOL
      AEI = AMEM*1000./VOL
      DO 44 I = 1, N
      READ 4, T(I), X(I)
      4 FORMAT(F4.0,5X,F5.0)
      IF(M - 1) 61,61,64
      61 IF(I - 1) 62,62,63
      62 C = EXP(-2.303*A0/A1)/T(I)
      63 T(I) = T(I)*C
      ESTM(I) = (A0 + A1*LOG(T(I))/2.303)*TM
      GO TO 44
      64 IF(I - 1) 65,65,66
      65 C=EXP(2.303*(-A1-SQRT(A1**2-4.*A2*A0))/(2.*A2))/T(I)
      66 T(I) = T(I)*C
      C1 = LOG(T(I))/2.303
      ESTM(I) = (A0 + A1*C1 + A2*C1**2)*TM
      44 Y(I) = LOG((TM - ESTM(I))/(AMEM - ESTM(I)))/2.303
      EXECUTE PROCEDURE 101
      PRINT 27, NM, ND, NY

```

```

27 FORMAT(/13H EXPERIMENTAL,10X,3HRUN,2X,I2,1H/,I2,1H/,I2//)
    PRINT 24, TM, AI, AMEM, AEI, AO, A1, RMSD
24 FORMAT(28X,7HINITIAL/19X,5HMOLES,16X,5HCONC.,/5H ACID,10X,E11.5,
110X,E11.5,/8H ALCOHOL,7X,E11.5,10X,E11.5,//17H LEAST SQUARE FIT/
2 5X,15HLOG(A-X/B-X) = ,E11.5,3H + ,E11.5,5H*TIME,10X,7HRMSD = ,
3E11.5//)
    PRINT 30
30 FORMAT( 5X,4HTIME,7X,9HPC TRANS.,3X,11HMOLES ESTER,2X,
112HLOG(A-X/B-X),5X,4HDEV./)
    DO 45 I = 1, N
    PRINT 25, X(I), T(I), ESTM(I), Y(I), DEV(I)
25 FORMAT(2XE11.5,2XE11.5,2XE11.5,2XE11.5,2XE11.5)
45 CONTINUE
    R = A1/(2.303*(AI - AEI))
    PI = LOG(AI/AEI)/2.303
    PRINT 26, AVG, R, PI, AO
26 FORMAT(34X,20HAVERAGE DEVIATION = ,E11.5//10X,15HRATE CONSTANT = ,
1 1X,E11.5/10X,22HPREDICTED INTERCEPT = ,E11.5/10X,
218HEXPT. INTERCEPT = ,E11.5)
    PRINT 28
28 FORMAT(/13X51HCOORDINATES OF POINTS GENERATED BY LEAST SQUARE FIT/,
119X,12HLOG(A-X/B-X),15X,4HTIME,/)
    H = 0.
    DO 46 J = 1, 2
    G = AO + A1*H
    PRINT 29, G, H
29 FORMAT(20X,E11.5,10X,E11.5)
46 H = 1.
    BEGIN PROCEDURE 101
C   LEAST SQUARE FIT Y(I) = AO + A1*X(I)
    SUMY = 0.
    SUMX = 0.
    SUMY2 = 0.
    SUMX2 = 0.
    SUMXY = 0.
    DO 141 I = 1, N
    SUMY = SUMY + Y(I)

```

```

SUMY2 = SUMY2 + Y(I)**2
SUMX = SUMX + X(I)
SUMX2 = SUMX2 + X(I)**2
141 SUMXY = SUMXY + X(I)*Y(I)
U = N
DEN = U*SUMX2 - SUMX**2
A0 = (SUMY*SUMX2 - SUMXY*SUMX)/DEN
A1 = (U*SUMXY - SUMX*SUMY)/DEN
SUMD2 = 0.
SUMD = 0.
DO 142 I = 1, N
DEV(I) = Y(I) - (A0 + A1*X(I))
SUMD2 = SUMD2 + DEV(I)**2
142 SUMD = SUMD + ABS(DEV(I))
RMSD = SQRT(SUMD2/U)
AVG = SUMD/U
END PROCEDURE 101
CONTROL 971
STOP
GO TO 1000
END

```

CALIBRATION DATE 3/ 10/ 67 LINEAR NUMBER OF POINTS 5

EXPERIMENTAL RUN 4/ 6/ 67

	MOLES	INITIAL CONC.
ACID	.25000E 00	.20145E 01
ALCOHOL	.24719E 01	.19918E 02

LEAST SQUARE FIT
LOG(A-X/B-X) = -.10333E 01 + -.44813E-02*TIME RMSD = .39705E-01

TIME	PC TRANS.	MOLES ESTER	LOG(A-X/B-X)	DEV.
.00000E-50	.20309E 02	.00000E-50	-.99491E 00	.38481E-01
.50000E 01	.16247E 02	.39786E-01	-.10631E 01	-.73324E-02
.15000E 02	.14964E 02	.54449E-01	-.10919E 01	.87104E-02
.30000E 02	.10689E 02	.11444E 00	-.12400E 01	-.72265E-01
.64000E 02	.98339E 01	.12930E 00	-.12877E 01	.32405E-01
AVERAGE DEVIATION =				.31838E-01

RATE CONSTANT = .10868E-03
PREDICTED INTERCEPT = -.99491E 00
EXPT. INTERCEPT = -.10333E 01

COORDINATES OF POINTS GENERATED BY LEAST SQUARE FIT
LOG(A-X/B-X) TIME

-.10333E 01	.00000E-50
-.12574E 01	.50000E 02

CALIBRATION DATE 3/ 10/ 67

LINEAR

NUMBER OF POINTS 5

EXPERIMENTAL

RUN 4/ 18/ 67

INITIAL

	MOLES	CONC.
ACID	.25000E 00	.20145E 01
ALCOHOL	.24719E 01	.19918E 02

LEAST SQUARE FIT

$$\text{LOG}(A-X/B-X) = -.10081E 01 + -.67129E-02*TIME$$

$$\text{RMSD} = .25448E-01$$

TIME	PC TRANS.	MOLES ESTER	LOG(A-X/B-X)	DEV.
.00000E-50	.20309E 02	.00000E-50	-.99491E 00	.13196E-01
.50000E 01	.18804E 02	.13722E-01	-.10170E 01	.24665E-01
.15000E 02	.13539E 02	.72294E-01	-.11302E 01	-.21433E-01
.30000E 02	.10530E 02	.11710E 00	-.12482E 01	-.38719E-01
.61000E 02	.84245E 01	.15689E 00	-.13953E 01	.22291E-01

$$\text{AVERAGE DEVIATION} = .24061E-01$$

$$\text{RATE CONSTANT} = .16280E-03$$

$$\text{PREDICTED INTERCEPT} = -.99491E 00$$

$$\text{EXPT. INTERCEPT} = -.10081E 01$$

COORDINATES OF POINTS GENERATED BY LEAST SQUARE FIT

LOG(A-X/B-X)	TIME
-.10081E 01	.00000E-50
-.13437E 01	.50000E 02

CALIBRATION DATE 3/ 10/ 67 LINEAR NUMBER OF POINTS 5

EXPERIMENTAL RUN 4/ 21/ 67

	MOLES	INITIAL	CONC.
ACID	.25000E 00		.20145E 01
ALCOHOL	.24719E 01		.19918E 02

LEAST SQUARE FIT
LOG(A-X/B-X) = $-.99922E 00 + -.37505E-02*TIME$ RMSD = $.99773E-02$

TIME	PC TRANS.	MOLES ESTER	LOG(A-X/B-X)	DEV.
.00000E-50	.20309E 02	.00000E-50	$-.99491E 00$	$.43133E-02$
.50000E 01	.18616E 02	.15514E-01	$-.10199E 01$	$-.20185E-02$
.15000E 02	.17093E 02	.30733E-01	$-.10464E 01$	$.90456E-02$
.30000E 02	.13539E 02	.72294E-01	$-.11302E 01$	$-.18494E-01$
.60000E 02	.11170E 02	.10659E 00	$-.12171E 01$	$.71541E-02$

AVERAGE DEVIATION = $.82052E-02$

RATE CONSTANT = $.90957E-04$
PREDICTED INTERCEPT = $-.99491E 00$
EXPT. INTERCEPT = $-.99922E 00$

COORDINATES OF POINTS GENERATED BY LEAST SQUARE FIT
LOG(A-X/B-X) TIME

$-.99922E 00$	$.00000E-50$
$-.11867E 01$	$.50000E 02$

CALIBRATION DATE 3/ 10/ 67

LINEAR

NUMBER OF POINTS 5

EXPERIMENTAL

RUN 4/ 26/ 67

	MOLES	INITIAL	CONC.
ACID	.25000E 00		.20145E 01
ALCOHOL	.24719E 01		.19918E 02

LEAST SQUARE FIT

$\text{LOG}(A-X/B-X) = -.10281E 01 + -.38525E-02*TIME$

RMSD = .32608E-01

TIME	PC TRANS.	MOLES ESTER	LOG(A-X/B-X)	DEV.
.00000E-50	.20309E 02	.00000E-50	-.99491E 00	.33229E-01
.15000E 02	.13539E 02	.72294E-01	-.11302E 01	-.44306E-01
.60000E 02	.10530E 02	.11710E 00	-.12482E 01	.11076E-01
AVERAGE DEVIATION =				.29537E-01

RATE CONSTANT = .93431E-04

PREDICTED INTERCEPT = -.99491E 00

EXPT. INTERCEPT = -.10281E 01

COORDINATES OF POINTS GENERATED BY LEAST SQUARE FIT

LOG(A-X/B-X)	TIME
-.10281E 01	.00000E-50
-.12207E 01	.50000E 02

Footnotes

1. Roberts, Irving, Harold C. Arey, Journal of the American Chemical Society 60, 2391(1938).
2. Barrow, Gordon M., Physical Chemistry (McGraw-Hill Book Company, Inc., New York, 1961) p. 349.
3. Glasstone, Samuel, Keith J. Laidler, Henry Eyring. The Theory of Rate Processes. (McGraw-Hill Book Company, Inc., London, 1941) p. 402
4. Barrow, op. cit., p. 369.
5. Instruction Manual for Perkin-Elmer Model 337 Spectrophotometer (Connecticut, 1963), p. 4.
6. Wilks Scientific Corporation, Internal Reflection Spectroscopy (Connecticut, 1965) pp. 1-3.
7. Ibid., p. 4.
8. Ibid., p. 11.
9. Ibid., p. 3.
10. Silverstein, Robert M., G. Clayton Bassler, Spectrometric Identification of Organic Compounds. (John Wiley and Sons, Inc., New York, 1963) p. 62.
11. Willard, Hobart H., Lynne L. Merritt, Jr., John A. Dean, Instrumental Methods of Analysis. (D. Van Nostrand Company, Inc., 4th edition, New York, 1965) p. 77.
12. Silverstein, op. cit., p. 64.
13. Bensen, Sidney W., The Foundation of Chemical Kinetics. (McGraw-Hill Book Company, Inc., New York, 1960) p. 87.

This thesis has been presented to the Faculty of the Department of Chemistry of Washington and Lee University and approved as partial fulfillment for the degree Bachelor of Science in Chemistry with Honors.

May 18, 1967